

# A mathematical model of glass flow and heat transfer in a platinum downspout

ROBERT DUCHARME,† PHIROZE KAPADIA,† FRED SCARFE‡  
and JOHN DOWDEN§

† Department of Physics, University of Essex, Colchester, Essex CO4 3SQ, U.K.

‡ Electroglass Ltd, 4 Brunel Road, Benfleet, Essex SS7 4PS, U.K.

§ Department of Mathematics, University of Essex, Colchester, Essex CO4 3SQ, U.K.

(Received 6 July 1992)

**Abstract**—The possibility of using a heat exchanger system to control the flow of glass through a platinum downspout is investigated. Downspouts are used in place of refractory throats since they avoid some of the problems associated with throats. It is assumed that the flow is predominantly axial and an integral expression for the flow field is obtained. The temperature distribution in the glass is calculated using the finite difference method. The formulation of the heat transfer problem includes a detailed analysis of the anisotropic radiation field in the glass.

## 1. INTRODUCTION

SOME GLASS tank furnaces of the ‘mixed melter’ type [1] are currently fitted with platinum downspouts, as outlets for the glass. The intention is to enable the extraction of the glass from the furnace to take place under the action of gravity forces. These furnaces are hexagonal in cross-section and have outputs of the order of 3 tonnes per day. The downspout is a circular tube of approximately 20 cm in length and 2 cm in diameter. Since the tube is made from platinum it has the advantage that it is strongly resistant to corrosion and therefore does not contaminate the glass. Downspouts are used in place of refractory throats. Throats are a weak point of traditional furnace design for two reasons. Firstly, because they are vulnerable to wear and therefore limit the operational lifetimes of furnaces. Secondly, if the continuous operation of glass manufacture is disrupted then there is a danger that the glass in the throat will freeze and render the furnace inoperable. Both of these problems can be overcome by use of a downspout.

The purpose of this paper is to investigate the possibility of using a heat exchanger system to control the flow rate through a downspout. The Navier–Stokes equations in the form that allows for spatial variations in viscosity are taken as a starting point and it is assumed that the flow is predominantly axial. An analytic solution for the flow field in the glass is then obtained. The pressure gradient is determined as a function of axial position from the condition that the mass flow rate through the tube must be a constant; since the variation in density will be small, the mass flow rate is effectively the same as the volume flow rate.

Numerical solutions for the temperature distribution in the downspout are computed using the finite difference method. This technique has been used

in the past to predict isotherm patterns inside tank furnaces [2] and also to compute temperature distributions in plate glass under a variety of different boundary conditions [3]. One further consideration here is that the diameter of a downspout is so small that the radiation field cannot be assumed isotropic. The Rosseland approximation used to calculate the contribution of radiation to heat transfer in glass furnace models is therefore unsuitable. The radiative flux must therefore be calculated from the full form of the radiative transport equation. This is integrated twice by parts to separate out the Rosseland approximation and some additional differential terms. The remaining integral term is then small and can be calculated using a simple iterative scheme.

To simulate cooling in the downspout it is assumed that the glass enters at a constant temperature and loses heat through the platinum. The inside wall of the downspout is itself modelled as an isothermal surface. The analysis has two main objectives. The first is to calculate flow and temperature fields in the glass as a function of time and to explain some of their features. The second is to determine the relationship between the degree of cooling that is applied to the downspout and the flow rate through it. This includes a calculation of the minimum amount of cooling that is needed in order to shut the flow off completely.

## 2. THE EQUATIONS OF MOTION

A downspout consists of a platinum tube of uniform circular cross-section (see Fig. 1). This is inserted through the bottom of a tank furnace and forms an outlet for the glass. The excess pressure at the top of the downspout is determined by the depth  $H$  of the melt in the furnace and may be expressed as

$$p_s = H\rho g$$

## NOMENCLATURE

$\exp(-A), B, T'$	constants in the formula for viscosity of glass (P, K, K)	$n_g$	refractive index
$a$	radius of downspout [m]	$\mathbf{q}, q_r$	radiative flux vector and $r$ -component [W m <sup>-2</sup> ]
$C_p$	specific heat at constant pressure [J kg <sup>-1</sup> K <sup>-1</sup> ]	$(r, z)$	cylindrical polar coordinates
$\mathbf{g}, g$	acceleration due to gravity [m s <sup>-2</sup> ]	$Re$	Reynolds number
$H$	depth of melt in furnace [m]; Heaviside step function	$s, s', s_0$	path length, and its origin [m]
$I, I_+$	intensity [W m <sup>-2</sup> ]	$S$	source function [W m <sup>-2</sup> ]
$I_1, I_2, I_3, R, U_{ij}, F_i, \Lambda, \Lambda^*$	special integrals, defined in the text	$t$	time [s]
$k_c$	thermal conductivity of the glass [J m <sup>-1</sup> s <sup>-1</sup> K <sup>-1</sup> ]	$T_B, T_0$	constants [K]
$k_r$	coefficient of radiative conductivity [J m <sup>-1</sup> s <sup>-1</sup> K <sup>-1</sup> ]	$T$	temperature [K]
$Ki_n$	repeated integrals of $K_0$ , the modified Bessel function of the second kind	$\mathbf{u}, (u, v, w)$	velocity vector [m s <sup>-1</sup> ]
$L$	length of downspout [m]	$\dot{V}$	volume rate of flow [m <sup>3</sup> s <sup>-1</sup> ].
$\mathbf{m}, m_r$	unit vector in direction of radiation intensity and $r$ -component	Greek symbols	
$M, P$	heat dissipation [W], mass flow rate [kg s <sup>-1</sup> ]	$\alpha$	defined in text following equation (18)
$p$	pressure [N m <sup>-2</sup> ]	$\Gamma, \chi, \phi, Y, \Sigma$	constants [W m <sup>-2</sup> ], [m <sup>-1</sup> ], [—], [J m <sup>-1</sup> s <sup>-1</sup> K <sup>-1</sup> ], [W m <sup>-2</sup> ]
$p_s$	pressure at the top of the downspout [N m <sup>-2</sup> ]	$\varepsilon$	coefficient of emissivity of platinum
$p_0$	reference pressure at bottom of downspout [N m <sup>-2</sup> ]	$\Theta$	angle of inclination
		$\mu$	viscosity of glass [P]
		$\rho$	density of glass [kg m <sup>-3</sup> ]
		$\sigma$	Stefan-Boltzmann constant [W m <sup>-2</sup> K <sup>-4</sup> ]
		$\Phi$	azimuth angle
		$\Omega$	surface of the unit sphere.

where  $\rho$  is the density of the glass and  $g$  is the acceleration due to gravity. The reference pressure at the bottom of the downspout is given by  $p_0 = 0$ .

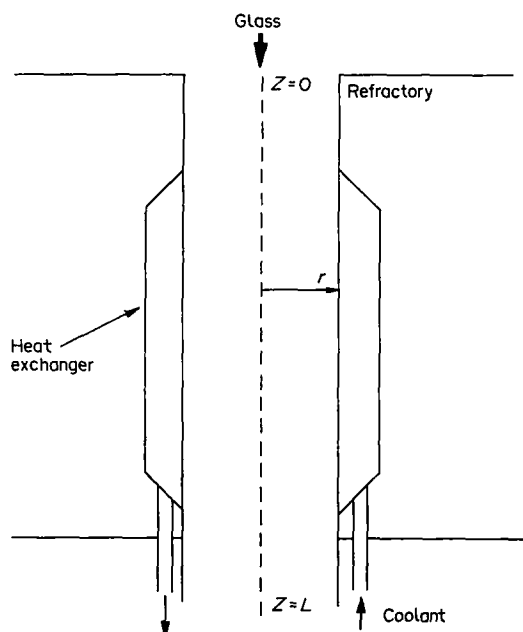

FIG. 1. Geometry of the downspout.

The flow rate through a downspout can be influenced using a heat exchanger system. One possible form of this device is indicated in Fig. 1 and consists of a metal coil (or jacket) fixed around the downspout. Compressed air is circulated through the heat exchanger and cools the glass. The effect of this on viscosity can be studied through the Fulcher-Tamman equation

$$\mu = \exp \{ B / (T - T') - A \}$$

where  $A, B$  and  $T'$  are constants which depend on the chemical composition of the glass and  $T$  is temperature. It is instructive to note that the solidification of glass is a gradual process and is characterised by a discontinuous change in viscosity. One useful consequence of this is that the cooling of glass in a downspout does not have to be treated as a two phase problem. No appeal to ideas about moving boundaries need therefore be made.

Flow in a downspout is usually characterised by a low Reynolds number ( $Re \ll 1$ ). The implications of this are first that the flow is laminar and second that the inertial terms in the Navier-Stokes equations describing the flow can be neglected [4]. In vector notation the equations of motion for the glass can

therefore be expressed as

$$\nabla \cdot \mathbf{u} = 0$$

and

$$\nabla p + \rho \mathbf{g} = \mu \nabla^2 \mathbf{u} + 2\nabla \mu \cdot \nabla \mathbf{u} + \nabla \mu \times (\nabla \times \mathbf{u}) \quad (1)$$

where  $\mathbf{u} = (u, v, w)$  is the fluid velocity. The first of these results is a description of the incompressibility of the glass. Expression (1) is the set of Navier–Stokes equations for an incompressible Newtonian fluid [5]. The density of the glass has been assumed constant in both these results. Natural convection in the tube can be neglected because the forced convection due to gravity forces is a much more important process.

### 3. CALCULATION OF THE FLOW FIELD

The flow in a downspout is axisymmetric. Since the length  $L$  of the downspout is much larger than its radius  $a$  it is also reasonable to assume that the flow is predominantly axial. Hence in terms of cylindrical polar coordinates  $(r, z)$  equation (1) can be simplified to give

$$\frac{dp}{dr} = 0$$

and

$$\frac{dp}{dz} + \rho g = \frac{1}{r} \frac{d}{dr} \left[ r \mu \frac{dw}{dr} \right] \quad (2)$$

having neglected all terms containing a radial velocity and axial derivatives of  $\mu$  or  $w$ . The principle of conservation of mass in this case can usefully be expressed in the integral form

$$\dot{V} = 2\pi \int_0^a r w \, dr \quad (3)$$

where  $\dot{V}$  is the volume flow rate through the tube. Integrating equation (2) twice with respect to  $r$  and applying the no-slip boundary condition

$$w = 0 \quad \text{at} \quad r = a$$

yields

$$w = \frac{1}{2} \left\{ \frac{dp}{dz} + \rho g \right\} \int_r^a [\mu(r', z)]^{-1} r' \, dr'. \quad (4)$$

The pressure gradient in this expression can be calculated from equation (3) to give

$$\frac{dp}{dz} = \frac{p_0 + \rho g L}{I_2(a, z) I_3(a, L)} - \rho g$$

where

$$I_1(r, z) = \int_r^a [\mu(r', z)]^{-1} r' \, dr'$$

$$I_2(a, z) = \int_0^a I_1(r, z) r \, dr$$

$$I_3(r, z) = \int_0^L [I_2(a, z)]^{-1} dz.$$

These results shall henceforth be referred to as the formal solution of equation (2). Note that the integrals cannot be evaluated at this stage because the temperature has yet to be determined as a function of position.

### 4. THE HEAT TRANSFER EQUATION

The existing theory of heat transfer in pipes [6] is developed here to treat the flow of glass and in particular includes a detailed analysis of the radiation field in a semi-transparent medium. The differential equation of heat transfer under these circumstances is

$$\rho C_p \left[ \frac{\partial T}{\partial t} + w \frac{\partial T}{\partial z} \right] = \frac{1}{r} \frac{\partial}{\partial r} \left[ r k_c \frac{\partial T}{\partial r} - r q_r \right] \quad (5)$$

where  $q_r(r, T)$  denotes the  $r$ -component of the radiation flux,  $k_c$  is the thermal conductivity of the glass and  $C_p$  is the specific heat capacity. This equation includes an axial contribution from convection as well as radial contributions from conduction and radiation. It is thus assumed that convection is the dominant mode of heat transfer along the  $z$ -axis and that other axial terms can be neglected. This is reasonable so long as the flow rate has not been reduced so much that the convection is no longer strong.

Numerical solutions to equation (5) are to be sought subject to the boundary conditions

$$T(a, z) = T_B \quad (\partial T / \partial r)_{r=0} = 0,$$

and

$$T(r, 0) = T_0 \quad (6)$$

where  $T_B$  and  $T_0$  are constants if it is assumed that the axial temperature gradient in the wall of the downspout is relatively small. It is interesting to note that no condition is specified at its outlet. The reason for this is because it is assumed there is strong unidirectional flow of heat along the  $z$ -coordinate axis. The temperature at any point in the glass is therefore largely independent of conditions nearer to the end of the tube. Patankar [7] draws an analogy between this situation and time-dependent heat transfer. The temperature at a time  $t$  is subject to influences from the past but is independent of events in the future. The same marching integration can therefore be used to obtain solutions in both instances. The discretization and solution of equation (5) using the finite difference method is discussed in further detail in Section 8.

### 5. THE RADIATION FIELD

The diameters of furnace downspouts are sufficiently small to ensure the glass is moderately transparent to the radiation within the spout. The radiation field is therefore anisotropic and the dependence of the intensity of the radiation on angular direction must be taken into account. In what follows, the equation of radiative transfer is taken as a starting point and an integral expression for the flux  $q_r$  is obtained. For the purposes of an approximate calculation it shall be assumed that the absorption coefficient of the glass  $\chi$  is constant and that the source function  $S$  can be calculated using the Stefan-Boltzmann equation [8]

$$S = \frac{n_g^2 \sigma T^4}{\pi}$$

where  $n_g$  is the refractive index and  $\sigma$  is the Stefan-Boltzmann constant.

The radiative flux vector  $\mathbf{q}$  is the first moment of the radiation field integrated over all angular directions and is given by the expression

$$\mathbf{q} = \oint \mathbf{m} I d\Omega.$$

In this,  $\mathbf{m}(\Theta, \Phi)$  is a unit vector in the direction of a pencil of radiation of intensity  $I$ ,  $\Theta$  ( $0 \leq \Theta \leq \pi$ ) is the angle of inclination of  $\mathbf{m}$  to the vertical and  $\Phi$  ( $0 \leq \Phi \leq 2\pi$ ) is the azimuth angle (see Fig. 2). The  $r$ -component of  $\mathbf{q}$  can be expressed [9] as

$$q_r = \oint m_r I d\Omega \quad (7)$$

where

$$m_r = \sin \Theta \cos \Phi_c.$$

The intensity  $I(s, m)$  can be calculated using the path integral form of the radiative transfer equation. In the case of a non-scattering medium this can be expressed [10] as

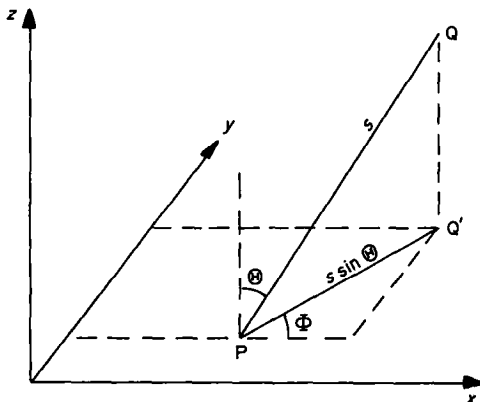

FIG. 2. An arbitrary path length  $s$  referred to a system of cartesian coordinates.

$$I = \Gamma \exp[-\chi(s_0 - s)] - \int_s^{s_0} S(T) \exp[-\chi(s' - s)] ds' \quad (8)$$

where  $s$  is a path length in the direction of  $\mathbf{m}$  and  $s = s_0$  at the boundary. For present purposes it is useful to adopt the convention of calculating  $I$  at the point  $s = 0$ . This leads to a simpler transfer equation but it is important at the same time to remember that  $g(s' - s)$  must replace  $g(s')$  whenever  $s \neq 0$ . A similar argument applies to functions of  $g(s_0)$ . Integrating equation (8) twice by parts leads to

$$I = \Gamma \exp(-s_0 \chi) - \left[ S + \frac{1}{\chi} \frac{dS}{ds} \right]_{s=s_0} \times \exp(-s_0 \chi) + S + \frac{1}{\chi} \frac{dS}{ds} + R \quad (9)$$

where

$$R = \int_0^{s_0} \frac{1}{\chi} \frac{d^2 S}{ds'^2} \exp(-\chi s') ds' \quad (10)$$

is the remainder term. Equation (9) is the starting point for the integro-differential equation technique. This is an iterative procedure using  $R = 0$  as an initial guess.

The constant  $\Gamma$  is equal to the intensity of the radiation entering the glass through the boundary at  $r = a$ . In terms of the special coordinates ( $s, \Theta, \Phi$ ) this condition can be expressed as

$$\Gamma = I \quad \text{at} \quad s_0 = 0.$$

For diffusively emitting and reflecting boundaries then

$$\Gamma = \varepsilon S(T_b) + \frac{(1-\varepsilon)}{\pi} \oint I_+(a, z) m_r d\Omega \quad (11)$$

where  $I_+(a, z)$  is the intensity of the radiation incident on the boundary,  $\varepsilon$  is the coefficient of emissivity of the platinum and  $(1-\varepsilon)$  is the corresponding coefficient of reflectivity.

### 6. THE TRANSFORMATION OF COORDINATES

Let  $r$  and  $r'$  denote the radial positions of two points referring to a system of cylindrical polar coordinates. The transformation relating  $(r', \Theta, \Phi)$  coordinates to a system of spherical polars  $(s, \Theta, \Phi)$  with origin  $r$  can then be obtained with the help of Figs. 2 and 3. Use of the cosine rule gives

$$(\sin^2 \Theta) s^2 + (2r \sin \Theta \cos \Phi) s + r^2 - r'^2 = 0. \quad (12)$$

This is a quadratic equation in  $s$  and has the solution

$$s(\mp) = \frac{-r \cos \Phi \mp (r'^2 - r^2 \sin^2 \Theta)^{1/2}}{\sin \Theta}. \quad (13)$$

There are three important cases to consider :

- (i) If  $r < r'$  then both roots of equation (12) are real

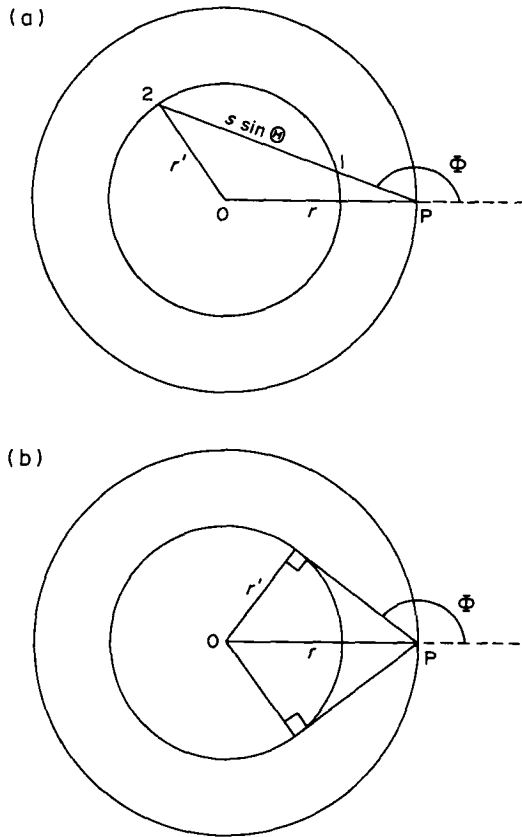

FIG. 3. The projection of  $s$  on to the horizontal plane through  $P$ .

but only  $s(+)$  is non-negative. The second root must therefore be rejected.

(ii) If  $r \geq r'$  and  $|\Phi - \pi| \leq \sin^{-1}(r'/r)$  then both roots are real and non-negative (see Fig. 3(a)). Two roots are needed because two points share the same  $(r', \Phi, \Theta)$  coordinates.

(iii) If  $r \geq r'$  and  $|\Phi - \pi| > \sin^{-1}(r'/r)$  then both roots are complex.

The angle separating cases (ii) and (iii) can be calculated using the construction in Fig. 3(b). The physical significance of this angle is clear from the diagram.

The path length operator  $d/ds$  can be obtained in component form using the chain rule for partial differentiation. This gives,

$$\frac{d}{ds} = \frac{dr}{ds} \frac{\partial}{\partial r} + \frac{d\Phi}{ds} \frac{\partial}{\partial \Phi}$$

where

$$\frac{ds}{dr} = \left[ \frac{\partial s}{\partial r} \right]_{r=r'} = -\operatorname{cosec} \Theta \sec \Phi$$

and

$$\frac{ds}{d\Phi} = \left[ \frac{\partial s}{\partial \Phi} \right]_{r=r'} = \operatorname{cosec} \Theta \operatorname{cosec} \Phi.$$

Furthermore, remembering that the source function is a function of temperature and that temperature is a function of a position and time it follows that

$$\frac{dS}{ds} = -m_r \frac{dS}{dr} \quad (14)$$

and

$$\frac{1}{\chi} \frac{dS}{ds} = \frac{3k_r}{4\pi} \frac{dT}{dr} \quad \text{where} \quad k_r = \frac{16n_s^2 \sigma}{3\chi} T^3 \quad (15)$$

is the coefficient of radiative conductivity.

In order to calculate the explicit form of  $s'(r, r', \Phi, \Theta)$  is it useful to note that

$$\frac{d}{ds} [s' - s]_{s=0} = -1.$$

Substitution of the generalised transformation

$$s'(\mp) = \frac{-r \cos(\Phi + \phi) \mp [r'^2 - r^2 \sin^2(\Phi + \phi)]^{1/2}}{\sin \Theta}$$

( $\phi = \text{constant}$ ) into this expression then yields  $\phi = \mp \pi$ . Thus,

$$s'(\mp) = \frac{r \cos \Phi \mp [r'^2 - r^2 \sin^2 \Phi]^{1/2}}{\sin \Theta} \quad (16)$$

and

$$s_0 = s'(r, a, \Phi, \Theta) = \frac{r \cos \Phi + [a^2 - r^2 \sin^2 \Phi]^{1/2}}{\sin \Theta}.$$

Since the length of the tube is much greater than its diameter it is reasonable to neglect end corrections to these equations and to assume that the range of  $\Theta$  is the same as for an infinite tube (i.e.  $0 \leq \Theta \leq \pi$ ).

Differentiation of equation (16) with respect to  $r'$  gives

$$ds'(\pm) = \frac{\pm r' dr'}{\sin \Theta [r'^2 - r^2 \sin^2 \Phi]^{1/2}} \quad (17)$$

Inserting these results into the chain rule

$$\frac{d}{ds'} = \frac{dr'}{ds'} \frac{d}{dr'}$$

then leads to

$$\left[ \frac{dS}{ds'} \right]_{s'(\pm)} = \pm \alpha \frac{dS}{dr'}$$

and

$$\frac{d^2 S}{ds'^2} = \alpha^2 \left( \frac{d^2 S}{dr'^2} - \frac{1}{r'} \frac{dS}{dr'} \right) + \frac{1}{r'} \frac{dS}{dr'} \sin^2 \Theta \quad (18)$$

where  $\alpha = r'^{-1} \sin \Theta [r'^2 - r^2 \sin^2 \Phi]^{1/2}$ .

### 7. CALCULATION OF THE RADIATION FLUX

Substitution of equation (14) into (9) gives

$$I = \Gamma \exp(-s_0 \chi) - \left[ S - \frac{m_r}{\chi} \frac{dS}{dr} \right]_{r=a} \times \exp(-s_0 \chi) + S - \frac{m_r}{\chi} \frac{dS}{dr} + R. \quad (19)$$

The differential terms in equation (10) can be transformed in a similar manner but using expressions for primed differentials; see equations (17) and (18) in place of equation (10). The only remaining problem is then to calculate the new limits of integration. From careful consideration of the real positive roots of equation (16) it can be shown that

$$R = \int_{r_0}^a \left[ \alpha^2 \left( \frac{d^2 S}{dr'^2} - \frac{1}{r'} \frac{dS}{dr'} \right) - \frac{1}{r'} \frac{dS}{dr'} \sin^2 \Theta \right] \times \{ \exp[-\chi s'(+)] + H(r, r') \exp[-\chi s'(-)] \} \alpha^{-1} dr'$$

where

$$r_0 = \begin{cases} r, & \pi/2 \leq \Phi \leq 3\pi/2 \\ r |\sin \Phi|, & 0 \leq \Phi \leq \pi/2, 3\pi/2 \leq \Phi \leq 2\pi \end{cases}$$

and

$$H(r-r') = \begin{cases} 1, & r > r' \\ 0, & r \leq r' \end{cases}$$

is the Heaviside step function. This equation expresses the remainder term as the sum of contributions from all points inside the glass and all points on the glass-platinum boundary. There are two points to note. The first is that the lower limit of integration has been chosen to exclude impossible combinations of  $r'$  and  $\Phi$ . The second is that the integrand contains two terms if two points happen to share the same ( $r', \Theta, \Phi$ ) coordinates, and one term otherwise.

The radiation flux in the glass can be calculated from equation (7). Inserting equation (19) into this expression and interchanging the order of integration gives

$$q_r = 2\pi(\Gamma - S)U_{10}(a, r) + \frac{3}{2} \left[ k_r \frac{dS}{dr} \right]_{r=a} U_{20}(a, r) - k_r \frac{dT}{dr} + \Lambda \quad (20)$$

where

$$\Lambda = \frac{3}{2} \int_0^a \left\{ \left[ \frac{d}{dr'} \left( k_r \frac{dI}{dr'} \right) - \frac{k_r}{r'} \frac{dI}{dr'} \right] U_{11}(r', r) + \frac{k_r}{r'} \frac{dI}{dr'} U_{1-1}(r', r) \right\} dr'$$

is the contribution of the  $R$  integral to the radiation flux. The  $U_{ij}(r', r)$  function is defined as

$$U_{ij}(r, r') = 2\pi^{-1} \int_0^\Phi \{ Ki_n(\chi x) + H(r-r') Ki_n(\chi y) \} \cos^i(\Phi) \beta^j(r, r', \Phi) d\Phi$$

where

$$\begin{aligned} x(r, r', \Phi) &= s'(+)\sin\Theta \\ y(r, r', \Phi) &= s'(-)\sin\Theta \\ \beta(r, r', \Phi) &= r'^{-1} [r'^2 - r^2 \sin^2 \Phi]^{0.5} \end{aligned}$$

$$n = |i| + |j| + 2$$

and

$$\Phi_0 = \pi - H(r-r') [\pi - \sin^{-1}(r'/r)].$$

Here the symbol  $Ki_n(Z)$  denotes the repeated integral

$$Ki_n(Z) = \int_{-\infty}^{\infty} Ki_{n-1}(t) dt \quad (n = 1, 2, 3, \dots)$$

where  $Ki_0(Z) = K_0(Z)$  is a modified Bessel function of the second kind [11].

The last step in calculating the radiation flux is to integrate equation (11) for  $\Gamma$ . The procedure is similar to the calculation of equation (20) and gives

$$\Gamma = S(T_b) + \frac{(1-\epsilon)|1+3F_2|}{1-2(1-\epsilon)F_1} \frac{2}{3} \left[ \frac{dS}{dr} \right]_{r=a} + (1-\epsilon) \{ \pi [1-2(1-\epsilon)F_{10}]^{-1} \Lambda(a)$$

where

$$F_i = 2\pi^{-1} \int_0^{\pi/2} Ki_n |2a\chi \cos \Phi| \cos^i \Phi d\Phi = U_{i0}(a, a) - (-1)^i (1+i)^{-1}.$$

Substituting this result into equation (20) and simplifying the subsequent expression one obtains,

$$q_r = k_r \frac{dT}{dr} + Y \left[ \frac{dT}{dr} \right]_{r=a} + \Lambda^* \quad (21)$$

where

$$Y = k_r(a) \left\{ \frac{(1-\epsilon)|1+3F_2|}{1-2(1-\epsilon)F_1} U_{10}(r, a) + 1.5 U_{20}(r, a) \right\}$$

and

$$\Lambda^*(r) = \Lambda(r) + \frac{2(1-\epsilon)U_{10}(r, a)}{1-2(1-\epsilon)F_1} \Lambda(a).$$

Equation (21) completes the mathematical formulation of the heat transfer problem. It is useful to note that

$$q_r(a, z) = 0 \quad \text{whenever } \epsilon = 0.$$

This condition is exact and states that a perfectly reflecting boundary cannot absorb radiation. It is an instructive exercise to show that equation (21) does indeed have this property.

### 8. NUMERICAL SOLUTION

Numerical solutions of equation (5) and conditions (6) can be obtained using a suitable finite difference scheme. The first step is to combine equations (5) and (21) to give

$$\rho C_p \left[ \frac{\partial T}{\partial t} + w \frac{\partial T}{\partial z} \right] = \frac{1}{r} \frac{\partial}{\partial r} \left[ r k_\epsilon \frac{\partial T}{\partial r} + r \Sigma \right] \quad (22)$$

where

$$\Sigma = -Y \left[ \frac{\partial T}{\partial r} \right]_{r=a} - \Lambda^* \quad \text{and} \quad k_c = k_c + k_r.$$

The nature of the heat transfer problem in a downspout has been discussed in detail in Section 4. To simulate cooling it shall be assumed that the temperature in the glass is equal to  $T_0$  at time  $t = 0$  and then satisfies conditions (6) for all  $t > 0$ .

The finite difference method is to be used to calculate the temperature  $T_i$  ( $i = 0, 1, 2, \dots, N$ ) at each of  $N$  grid points spanning the radius of the tube (see Fig. 5). The dashed lines and semi-circles in the diagram indicate the borders of subdomains. To obtain a finite difference equation at any particular grid point  $P$  equation (26) must be integrated over the subdomain surrounding it. In performing the integration it is assumed that the temperature varies linearly with  $r$ , between the grid points. The contribution of the convection term can be computed using marching integration. The time-dependent term is approximated using the assumption that the temperature changes from  $T(t)$  to  $T(t + \Delta t)$  at time  $t$  and then remains constant for the whole of the time step. The axial term is treated in a similar fashion. These considerations lead to the finite difference relation

$$a_p T_i(z, t) = a_n T_{i+1}(z, t) + a_s T_{i-1}(z, t) + b_2 T_i(z - \Delta z, t) + b_1 T_i(z, t - \Delta t) + r_n \Sigma_n - r_s \Sigma_s$$

where

$$\begin{aligned} a_n &= (k_c r)_n \delta r_n^{-1} & a_s &= (k_c r)_s \delta r_s^{-1} \\ b_2 &= w_i(z, t) \rho C_p \Delta A / \Delta z & b_1 &= \rho C_p \Delta A / \Delta t \\ a_p &= a_n + a_s + b_2 + b_1 & \Delta A &= 0.5(r_n + r_s) \Delta r. \end{aligned}$$

Here the subscripts  $n$  and  $s$  refer to the north and south faces of each subdomain. The meaning of the distances  $\delta r$  and  $\Delta r$  is illustrated in Fig. 4. Note a non-uniform grid mesh is used because large temperature gradients exist in the glass nearest to the tube wall. It is therefore economical in computer time to concentrate more grid points in this region.

Equation (22) can be solved using the tri-diagonal matrix algorithm (TDMA). The temperature-dependent coefficients are handled using iteration. First the temperature profile is calculated at each of a finite number of locations spanning the tube axis. The solution is then marched forward one time step and the calculation is repeated. This process can be continued until the steady state situation is reached. Note the flow field is recalculated after each application of the TDMA using the formal solution of the Navier-Stokes equations presented in Section 3.

## 9. DISCUSSION OF THE NUMERICAL RESULTS

The radiative conductivity of glass depends on temperature and can be calculated using equation (15). It is helpful to re-express this formula in the form

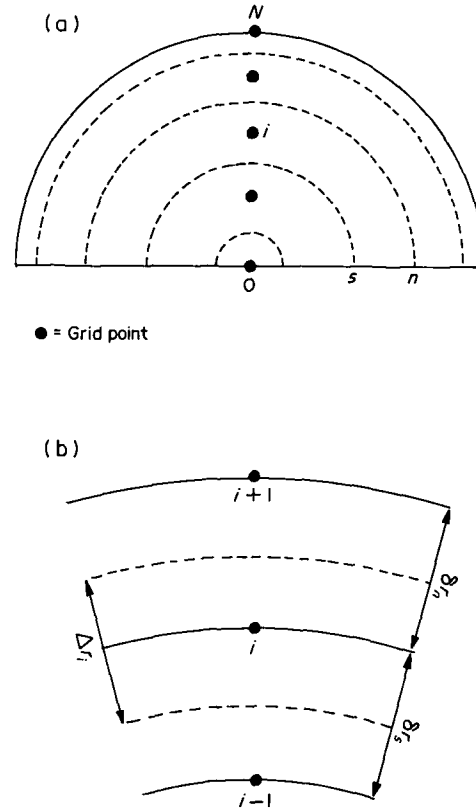

FIG. 4. (a) The finite difference mesh; (b) the meaning of the distance  $\delta r$  and  $\Delta r$ .

$k_r = b_g T^3$  where  $b_g$  is a constant. Grove and Jellyman [12] have made measurements of the monochromatic absorption coefficients of a number of soda-lime glasses each containing a different proportion of iron oxide. The measurements were made at several temperatures between 20 and 1400°C. Grove [13] has averaged this data for the purposes of calculating radiative conductivities. For a colourless glass containing 0.02% iron oxide as an impurity his analysis gives

$\chi_R = 16 \text{ m}^{-1}$  and  $b_g = 4.25 \times 10^{-8} \text{ W m}^{-1} \text{ K}^{-4}$  ( $1000 < T < 1400^\circ\text{C}$ ). This figure is in fact characteristic for flint glasses in general but the opacities of coloured glasses can be larger (of the order  $100 \text{ m}^{-1}$ ). The significance of this is that darker glasses retain their heat for longer.

Figure 5 illustrates the development of flow and temperature profiles at the outlet of a downspout with time. Figure 6 depicts the steady state situation at a number of different positions along the axis of the tube. The results were computed for a diffusively reflecting surface ( $e = 0.25$ ) and are based on the following data:

$$\begin{aligned} \rho &= 2400 \text{ kg m}^{-3} & C_p &= 1400 \text{ J kg}^{-1} \text{ K}^{-1} \\ k_c &= 0.8 \text{ J m}^{-1} \text{ K}^{-1} & T_0 &= 1300^\circ\text{C} & T_B &= 1200^\circ\text{C} \\ a &= 1 \text{ cm} & L &= 20 \text{ cm} & H &= 1 \text{ m}. \end{aligned}$$

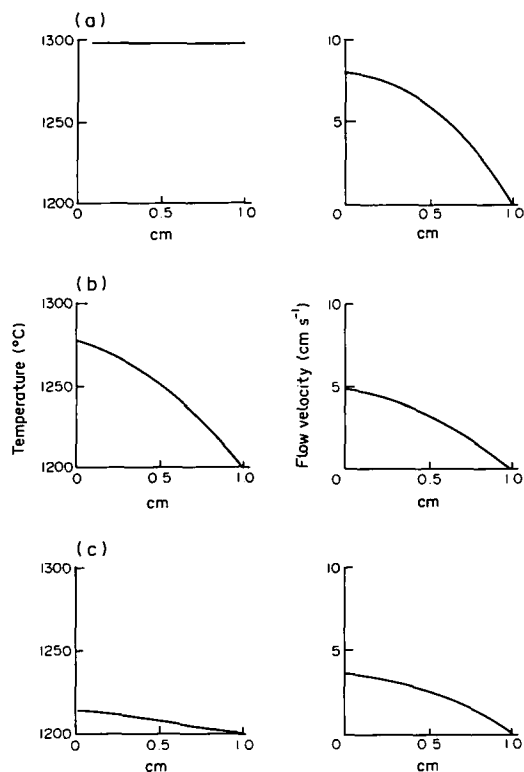

FIG. 5. The temperature and flow velocity at the end of a downspout as a function of the radial coordinate for different values of the time: (a)  $t = 0$  s; (b)  $t = 2$  s; (c)  $t = 10$  s.

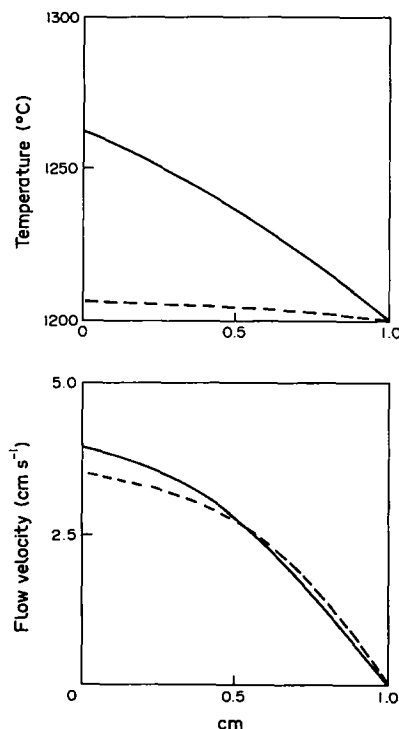

FIG. 6. Steady state flow and temperature profiles at two different positions on the  $z$ -axis.

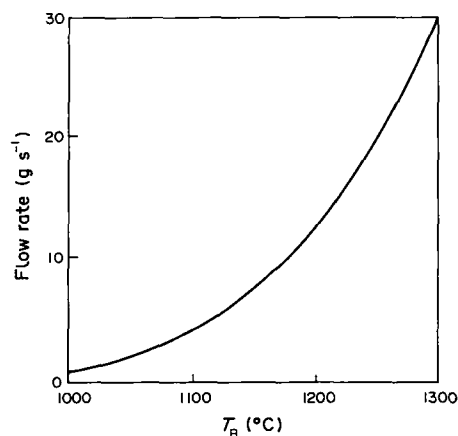

FIG. 7. The mass flow rate as a function of  $T_B$  for  $a = 1$  cm.

It can be seen from the graphs that the onset of cooling generates large temperature gradients in the glass and causes a rapid reduction in temperature throughout its entire volume. The effect of this on the flow is quite dramatic. It is notable that the cooling produces an almost 50% reduction in the flow rate in just 2 s. Two bulk properties of the flow of special interest here are the mass flow rate  $M = \rho V$  and the heat dissipation  $P$ . Under steady state conditions  $P$  can be expressed as

$$P = MC_p T_0 - 2\pi\rho C_p \int_0^a (wT)_{z=L} r dr.$$

This is just the difference between the energy of the glass entering and leaving the tube in one second. Since the system is assumed to be in a steady state the total energy within the downspout is itself a constant.

Graphs of  $M$  and  $P$  as a function of the temperature  $T_B$  of the platinum are presented in Figs. 7 and 8. It is clear from the first graph that the flow rate is a sensitive function of  $T_B$ . This is an encouraging result and suggests the flow should be easily controllable. One interesting feature of the second graph is that

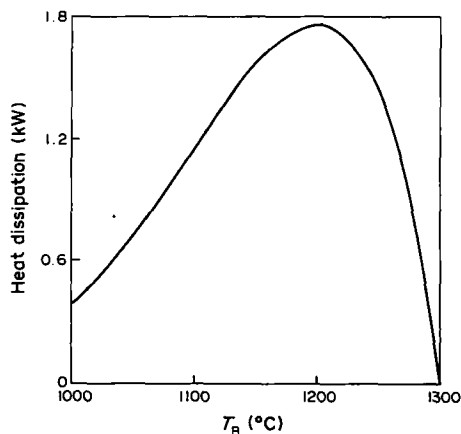

FIG. 8. The heat dissipation as a function of  $T_B$  for  $a = 1$  cm.



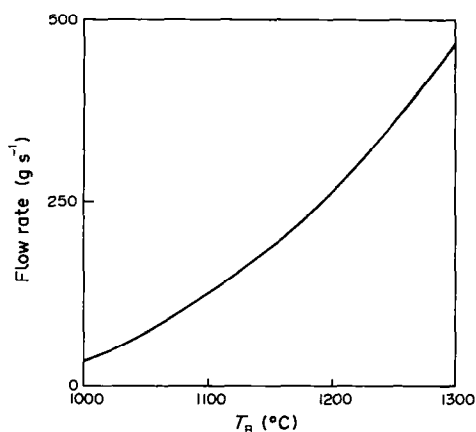

FIG. 9. The mass flow rate as a function of  $T_B$  for  $a = 2$  cm.

it has a maximum. This turning point indicates the minimum power dissipation needed to shut off the flow completely. It can be seen that for a tube of radius  $a = 1$  cm this is about 1.8 kW. For purposes of comparison Figs. 9 and 10 shows graphs of the flow rate and the power dissipation for a tube of radius 2 cm. It is instructive to note that the flow rate in the absence of cooling is sixteen times greater through the large tube than in the smaller one. The minimum heat dissipation needed to stop flow is seen to be about ten times larger. The upshot of this is that more elaborate and expensive heat exchanger system would be

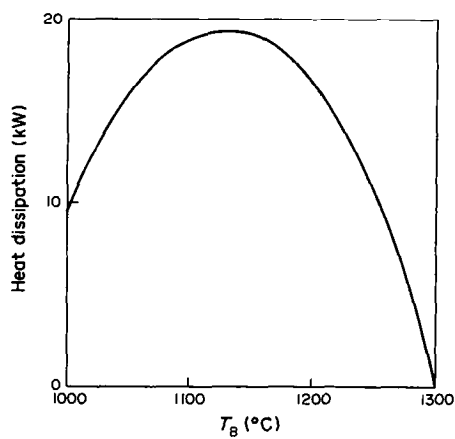

FIG. 10. The heat dissipation as a function of  $T_B$  for  $a = 2$  cm.

required to extract a disproportionately large amount of heat through a surface area of platinum that is only double that for a 1 cm tube.

One other reason high flow rates ( $M > 100 \text{ g s}^{-1}$ ) are more difficult to control than low flow rates is because the glass in the middle of a larger tube is more insulated. This is important because the first effect of cooling is to create large temperature gradients in a boundary layer region close to the tube wall. This in turn reduces the flow rate and enables the gradual freezing to penetrate deeper into the glass. The problem that arises is that the flow of hot glass through the middle of the tube tends to persist for a period of several minutes after the onset of cooling. This time lag is increased still further if a coloured glass is used or if the cooling is applied to only a part of the length of the downspout rather than along its full length. In practice, the flow rate of the coolant is important; so also is the construction of the jacket around the downspout and the entry and exit points for the coolant.

#### REFERENCES

1. F. Scarfe, Electric melting, a review, *Glass Technol.* **21**(1), 37–50 (1980).
2. A. Moulton, Two and three dimensional models of glass tank furnaces, *Glass Technol.* **23**(2), 106–112 (1982).
3. Tang He Ping and M. Lallemand, Transient radiative-conductive heat transfer in flat glasses submitted to temperature, flux and mixed boundary conditions, *Int. J. Heat Mass Transfer* **32**, 795–810 (1989).
4. G. K. Batchelor, *An Introduction to Fluid Dynamics*, p. 147. Cambridge University Press, Cambridge (1967).
5. J. Happel and H. Brenner, *Low Reynolds Number Hydrodynamics*. Prentice Hall, Englewood Cliffs, New Jersey (1965).
6. J. R. Simonson, *An Introduction to Engineering Heat Transfer*. McGraw-Hill, New York (1967).
7. S. V. Patankar, *Numerical Heat Transfer and Fluid Flow*. Hemisphere, Washington, D.C. (1980).
8. R. Gardon, A review of radiant heat transfer in glass, *J. Am. Ceram. Soc.* **44**(7), 305–312 (1961).
9. K. K. Sen and S. J. Wilson, *Radiative Transfer in Curved Media*. World Scientific, Singapore (1990).
10. D. Mihalas and B. W. Mihalas, *Foundations of Radiation Hydrodynamics*. Oxford University Press, Oxford (1984).
11. M. Abramowitz and I. A. Stegun, *Handbook of Mathematical Functions*, p. 483. Dover, New York (1970).
12. F. J. Grove and P. E. Jellyman, Infrared transmission of glass in range room temperature to 1400°, *J. Soc. Glass Technol.* **39**(186), 3–15 (1955).
13. F. J. Grove, Spectral transmission of glass at high temperatures and its application to heat transfer problems, *J. Am. Ceram. Soc.* **44**(7), 317–20 (1961).